

**TOOLS REQUIRED:**

- ✂ Tape Measure
- ✂ Carpenters Level
- ✂ Phillips Screwdriver
- ✂ 7/16" Wrench or Ratchet
- ✂ Drill and bits to match fasteners included

**Preparation**
**STEP 1**

**IMPORTANT:** Strips will be curled due to packing. It is highly recommended that you locate a flat, clean surface and lie the strips out flat for 24 hours, in a Warm Area, prior to installation. Strips installed in Freezer and Cooler Applications will NOT hang straight if installed while curled from packing or being rolled!

Compare the items received with the items ordered (Quantity & Sizes). If items are incorrect or missing call the factory immediately.

**Contents:**

- 1) Mounting Brackets (Front & Rear) See Figure 1a
- 2) Aluminum Angles (In-Jamb Mount Only) See Figure 1b
- 3) PVC Strips (Qty and Style Vary with Order)
- 4) Fasteners (Qty vary with opening size)
- 5) Installation Instructions

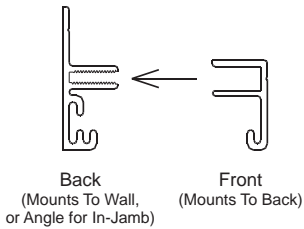
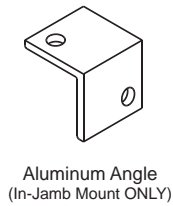
**Figure 1a**

**Figure 1b**
**STEP 2**

Determine the mounting method of your strip door. Figure 2a is a typical "Wall Mounting" method. Figure 2b shows a typical "In-Jamb Mounting" method. Continue at the right side of this page for Wall Mount Installation, go to page 2 for In-Jamb Mounting Installation.

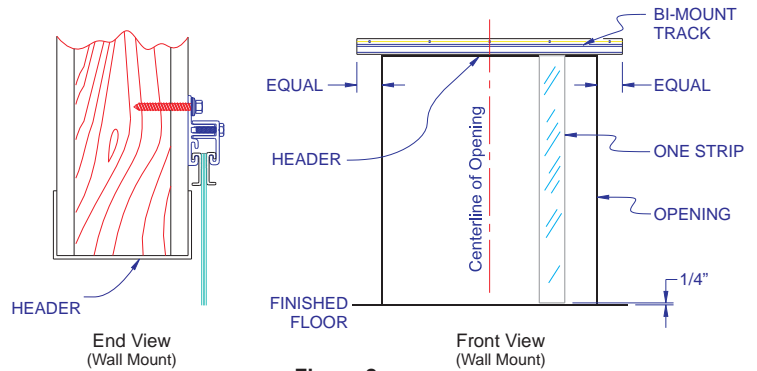
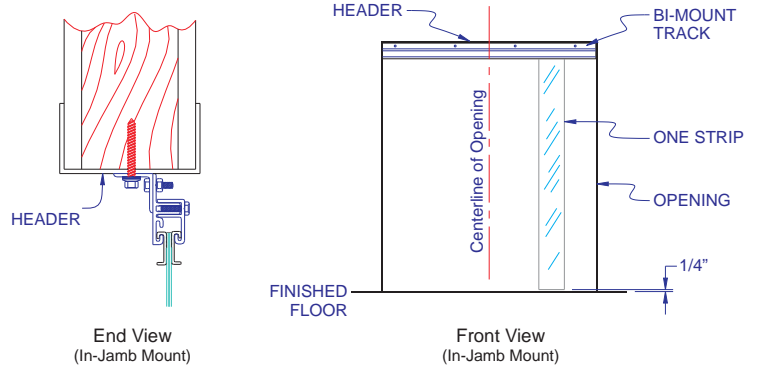
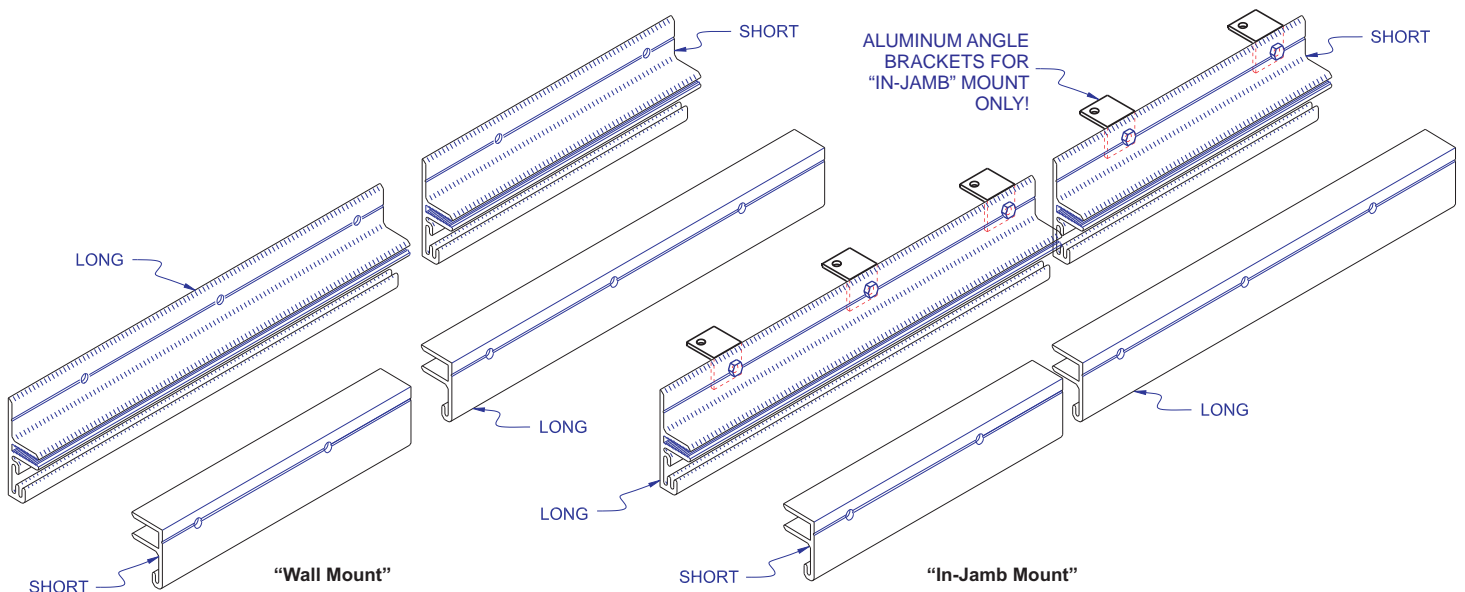
**IMPORTANT:** Refer to Figures 3 on Page 1 and Figure 8 on Page 2 before beginning the **HARDWARE INSTALLATION** section!

**Figure 2a**

**Figure 2b**
**"Bi-Mount" Hardware Placement**

**Figure 3**

**NOTE:** Due to shipping restraints we may be unable to ship the mounting brackets in lengths over 63". The brackets may be shipped as two pieces. To ensure proper installation and strength, it is highly recommended that you overlap the front and back mounting brackets as seen in Figure 3.

## "Wall Mount" Installation

### STEP 1

Clip a strip onto the Back mounting bracket as shown in Figure 4. Place the Back Mounting Bracket on the Wall above the Opening, see Figure 2a - Page 1. Position the bracket to allow the strip to hang straight down and 1/4" from the Finished Floor (See Figure 2a, Page 1). Use a level to be sure the Back Mounting Bracket is level. Use a Tape Measure to center the bracket above the opening. There should be an Equal Distance from the outside end of the bracket to the Jamb of the opening on both sides (See Figure 2a, Page 1).

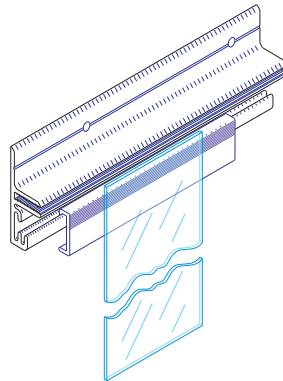

Figure 4

### STEP 2

After Establishing the position of the bracket, and leveling, mark the mounting holes and drill a pilot hole with the appropriate size drill bit for the fasteners being used.

### STEP 3

Insert the #10 x 2" Phillips Pan-Head Screws into the previously drilled holes and tighten securely, see Figure 5.

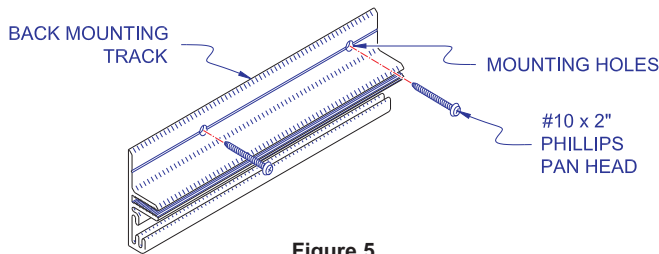

Figure 5

### STEP 4

Follow the "J-Hook" Strip Placement diagram below to place the PVC Strips. Continue to follow instructions below to install the front bracket and front row of strips.

## "In-Jamb Mount" Installation

### STEP 1

Locate the Aluminum Angle Brackets shown in Figure 1b - Page 1. There should be one angle bracket for every mounting hole on the back mounting bracket. Use the 1/4-20 x 1" Bolt with Nut to fasten the angle bracket to the back mounting bracket as shown in Figure 6. The top of the brackets should be flush with the top of the back bracket, refer to Figure 2b - Page 1.

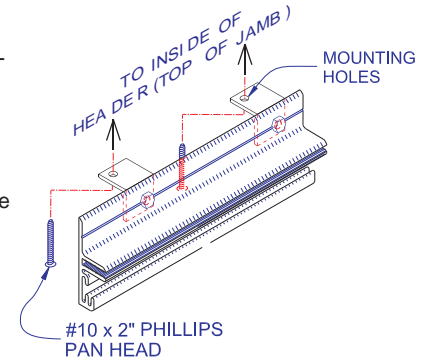

Figure 6

### STEP 2

Place the Back Mounting Bracket on the inside of the opening. Mounting track must be up against the header and against the Jamb on one side. Once in the desired position, mark all of the mounting holes on the Aluminum Brackets. Remove the bracket and drill pilot holes at marks using the appropriate drill bit for the fasteners being used.

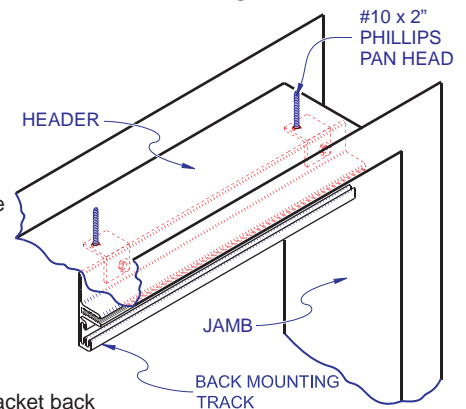

Figure 7

### STEP 3

Place the Back Mounting Bracket back into position and insert the #10 x 2" Phillips Pan Head screws into the previously drilled holes. Tighten securely.

### STEP 4

Follow the "J-Hook" Strip Placement diagram below to place the PVC Strips. Continue to follow instructions below to install the front bracket and front row of strips.

## "J-Hook" Strip Placement

### Rear Strips

The "END" Strips are labeled 1 - 4. These strips must be placed in the order shown in Figure 8 for proper overlap. The overlap has been figured for you at the factory according to the order placed. The "CENTER" Strips are identical and do not have to follow a designated order.

- 1) Begin with Strip #1 on the Back Mounting Bracket.
- 2) Place the Unmarked strips (one after another until you near the end of the Back Mounting Bracket.
- 3) Place Strip #2 at the end (Opposite #1).

### Front Strips

Loosely Mount the Front Bracket onto the Rear Bracket using the 1/4 - 20 Bolts Supplied (**DO NOT TIGHTEN FULLY AT THIS TIME**)

- 1) Begin with Strip #3 on the Front Mounting Bracket.
- 2) Place the Unmarked strips (one after another until you near the end of the Front Mounting Bracket.
- 3) Place Strip #4 at the end (Opposite #3).
- 4) Tighten bolts securely (Bolts are inserted into aluminum, **DO NOT OVER TIGHTEN**)

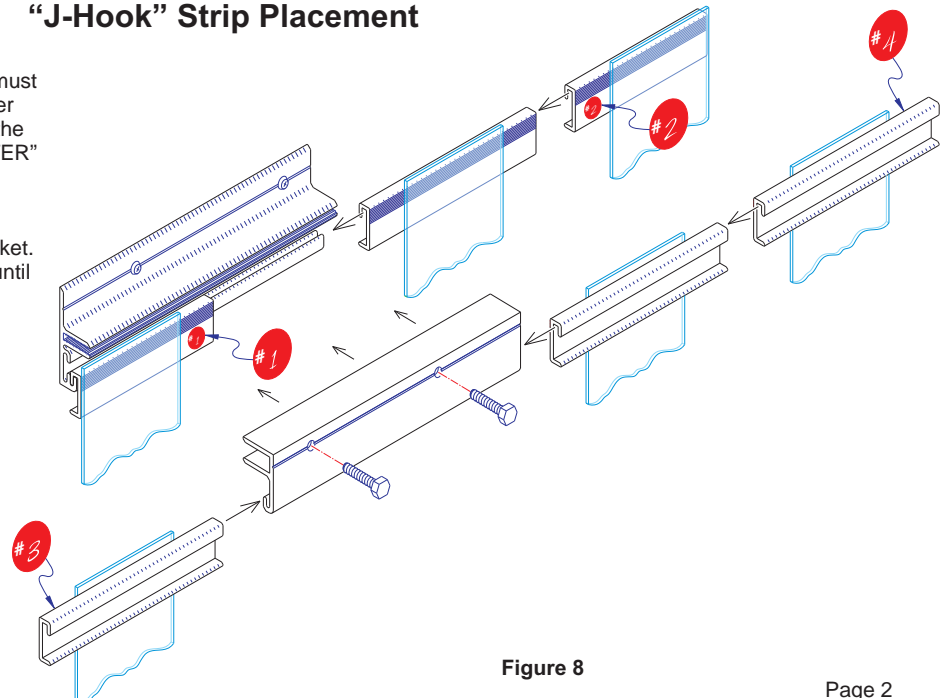

Figure 8